



Microfog

Models 35ES, 35EP,
9ES and 9EP

Operator's Handbook and Parts Catalogue

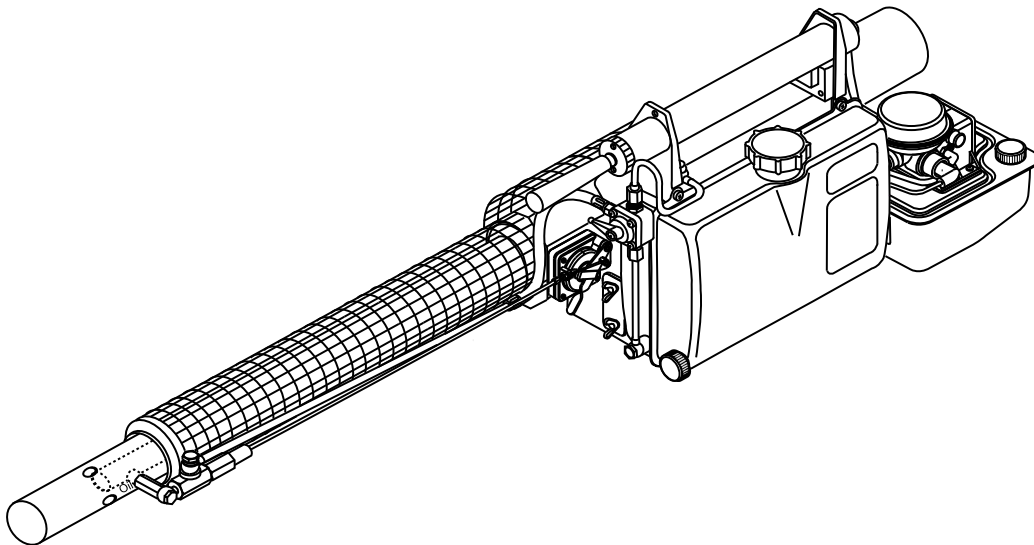

Table of Content

GENERAL INFORMATION	2
GUARANTEE	3
1. Principle of Operation	4
2. Technical Specifications	5
3. Standard Accessories	6
4. Optional Accessories	6
5. Safety Instructions	7-8
6. Preparation of Fogger for use	9-11
7. Selection of Solution Nozzle and Fog Tube	12
8. Preparation of Fogging Mixture	13
9. Starting the Fogger	14
10. If Fogger Stops Unexpectedly	15
11. Stopping the Fogger	16
12. Adjustment of Fuel/Air Mix	17
13. Maintenance & Storage	18-19
14. Trouble Shooting	20-22
15. Emergency Cut-off Device	23-24
16. Fogging with Emergency Cut Off	25
17. Stop the fogger with Emergency Cut Off	25
18. If Emergency Cut Off does not function correctl	26-27
Thermal Fogger 35ES, 9ES, 35EP, 9EP Exploded Drawing	28
Thermal Fogger 35ES, 9ES, 35EP, 9EP Spare Part List	
Emergency Cut-off Device Exploded Drawing	39
Emergency Cut-off Device Spare Part List	

1. General Information

Thank you for choosing MICROFOG thermal fogging unit.

Before using please read carefully this instruction manual. All the necessary information for an appropriate usage including assembly, operation, trouble shooting and maintenance is contained therein. Safety precautions should be taken into account throughout the lifetime of the unit. Only trained and qualified personnel are authorised to operate such equipment.

All Microfog thermal fogging units comply with EC Council Directive 2004/108/EC Electromagnetic Compatibility, they are manufactured and certified in accordance with international standards for equipment of this type.

Information in this manual is based on current knowledge. Technical improvement may be made without notice. Please feel free to contact us for update.

Definition of the symbols used:



The CE mark indicates that the fogger conforms to the EC directives.



General warning, risk of danger or possibility of damaging the fogger, pay particular attention to the words that follow this symbol.



All other relevant advice.

GUARANTEE

Micron Sprayers Ltd. guarantees the MICROFOG products for a period of 1 year from date of purchase for defective parts or manufacturing errors only.

We undertake to replace or repair, at the company's expenses, defective materials or components that fail under conditions of normal use within one year from the original date of purchase. Airofog does not responsible for any labour cost associated with the replacement of faulty components.

The guarantee is invalidated if damage occurs due to improper use/repair/maintenance, incorrect transport or handling, the use of non-recommended parts/products or acceptance of damaged/broken machines by any reason.

1. Principle of Operation

The Microfog thermal fogger models 35ES, 9ES, 35EP and 9EP operate on the pulse-jet principle. Air and fuel mixture from the carburetor is ignited in the combustion chamber that expels the exhausted gasses through resonator tube in a low frequency pulse.

At the end of the resonator, a fogging solution is injected into the exhausted gasses and atomized into fine aerosol droplets to create a fog. As the exhausted gasses are expelled, cold air is drawn in along the length of resonator tube through cooling jacket, temperature is low at the injection point of fogging solution at around 40~60 degree celcius and exposure time only 4-5 milliseconds, so active ingredients in the fog solution are not adversely affected by heat.

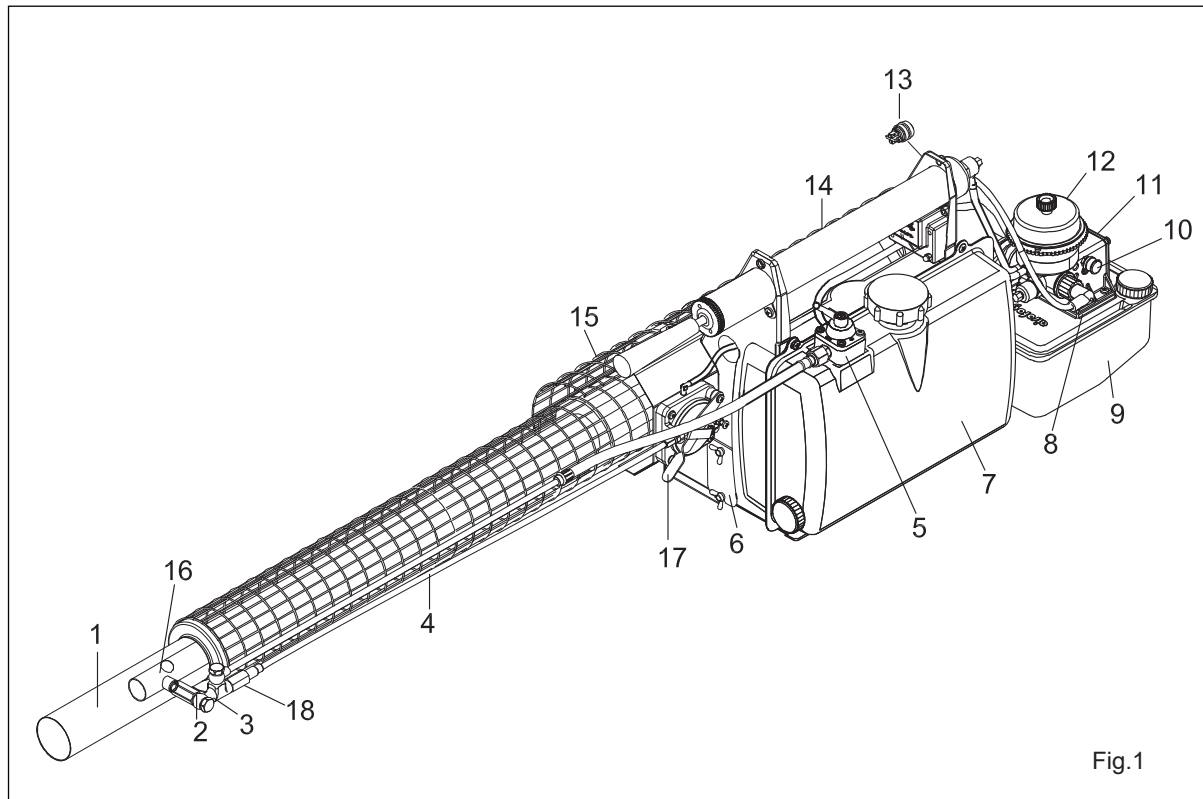

Fogger with Emergency Cut-off Device

1. Fog tube (108)
2. Solution socket (114)
3. Dosage nozzle (117)
4. Solution line (116)
5. Solution tap (120)
6. Battery cover (71)
7. Solution tank (1)
8. Swirl vane (26)
9. Gasoline tank (10)
10. Gasoline stop button (52)
11. Carburetor (23)
12. Air intake valve (30)
13. Starter button (78)
14. Air pump (89)
15. Cooling jacket (100)
16. Resonator (97)
17. Emergency cut-off device
18. Connecting piece Bowden cable

2. Technical Specifications:

Technical specifications are also applicable for 9EG & 35EG.

	9ES, 9EP	35ES 35EP
Combustion chamber output, approx.	11 KW/15 HP	18.7 KW/25.4 HP
Fuel tank made from stainless steel Capacity Fuel consumption, approx. Fuel	1.2 L 1.2 L/H standard grade gasoline, without any additives	1.2 L 2 L/H standard grade gasoline, without any additives
Solution tank made from stainless steel Total capacity	6 L	6 L
Ignition Electronic ignition coil, supplied from dry batteries size "LR20/D" or "LR6/AA" Spark plug	4 x 1.5 V not required	4 x 1.5 V not required
Weight (empty), approx. with emergency cut-off device	6.9 kg 7.3 kg	7.5 kg 7.9 kg
Dimensions Width x Height Length, with oil-base fog tube Length, with water-base fog tube	27 x 34 cm 114 cm 109 cm	27 x 34 cm 136 cm 131 cm

3. Standard Accessories:

	9ES, 9EP	35ES, 35EP
- Set of solution dosage nozzle	0.8 1.0 X	0.8 1.0 1.2
- Fuel funnel with strainer	√	√
- Solution funnel with strainer	√	√
- Set of repair tools	√	√
- Set of cleaning tools	√	√
- Tool bag	√	√
- Carrying strap	√	√
- Ear plug	√	√
- Diaphragm pack	√	√
- Instruction Manual	√	√

4. Optional Accessories:

- "LR6/AA" Battery holder
- Solution dosage nozzle
 - 0.6
 - 0.7
 - 1.4
 - 1.6
- Special fog tube for water

5. Safety Instructions:

- Please read the instructions carefully before using the fogger.
- Ensure instruction manual is kept with fogger at all times.
- Use the fogger only for the purpose it was designed for.
- Thermal foggers should ONLY be used by trained operators who are fully knowledgeable about the use of such machines.
- Operator should be aware of all protection and safety measures before use.
- Personnel with heart pacemakers should consult their doctors before operation due the fogger is started by using electronic ignition coil
- Before operation ensure the fogger is correctly assembled with no visible damage or leaks at joint, tube and hose. Do not fog if the fogger is not running perfectly.
- When fogging, use recommended personal protective equipment including respiratory and eye protection, ear defenders, gloves and coverall.
- During operation, never leave the fogger unattended.
- When using the carrying strap ensure the strap is placed over one shoulder ONLY and not accross the body for quick removal.
- Do not to touch hot parts due to danger of burning. After operations, allow reasonable time to cool down the fogger before further handling.
- Do not fog in the presence of people or animals. Avoid fogging directly against walls and fixed objects or near combustibile materials, keep a minimum distance of 3m.
- When fogging outdoors always carry the fogger with the fog tube pointing in the direction of the wind. If possible, hold the fog tube inclined downwards slightly.

-
- When fogging indoors, operator should always begin fogging away from exit and then walk towards direction of the exit. Avoid excessive fogging which could adversely affect visibility for a quick exit.
 - Follow chemical supplier's instructions for the safe use of the fog products.
 - Never apply pesticides, disinfectant or odour control products at application rates higher than the manufacturer's recommendation.
 - Never exceed quantity specified on product label when fogging within an enclosed space.
 - When filling with gasoline, make sure the fogger is not hot. Always use a funnel to fill the fuel tank and take care to avoid spillage.
 - Do not transport the fogger with fuel or solution in the tank, nor to transport fogger in vehicles while the fogger is still hot.
 - Do not fog combustible liquids into areas without ventilation to avoid fire risk.
 - Always keep a fire extinguisher at hand when working with combustible liquid.
 - Do not fog where there is a danger of dust explosion (e.g. grain mills).
 - Never invert or upset appliance which contains formulation or fuel.
 - For stationary operation, ensure fogger is mounted evenly on flat surface.
 - Always replace safety devices after maintenance or repairs.
 - Never modify the fogger.
 - Regularly check the seals or connectors for leaks, replace if necessary.
 - It is recommended to have the fogger maintained annually by qualified personnel.

6. Preparation of Fogger for Use:

The fogger comes packed in a cardboard box, check it is in undamaged condition after removing it from the box. It is only for packing purpose that fog tube is not fitted.



To avoid overheating the fogger, start the fogger **ONLY** after fog tube (108/109) is fitted (Fig. 2&3) with the resonator. The fog tube is reversible according to whether you will use oil or water mixtures.

To install the fog tube:

1) Pull out the fog tube (108) from the cooling jacket (100), select appropriate connection (oil base or water base) then push back the fog tube into the cooling jacket until the tube hole aligns with the resonator (97) thread. (Fig. 2)

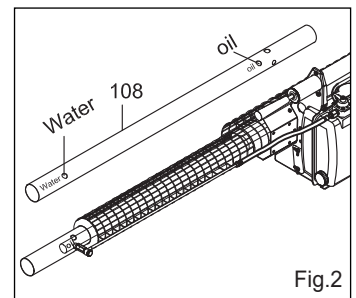

2) After screwing in the fog solution socket (114) by hand, join the solution dosage nozzle (117) to solution tube (116) together with copper gaskets (118) to the solution socket (114). It is necessary to use two spanners and counter hold the second spanner at the hexagon of the solution socket. (Fig. 3)

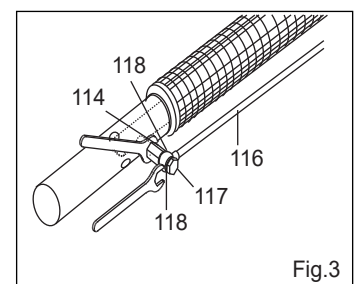

3) Insert batteries as per diagram. The positive pole is situated in front of the fuel tank (10) and the negative pole on the battery cover (71). (Fig. 4)

 For better performance, use Alkaline batteries.

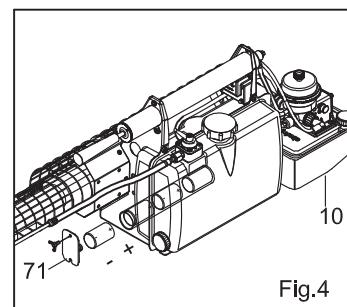

4) Check ignition coil by pressing starter button (78). A buzzing sound should be audible. (Fig. 5)

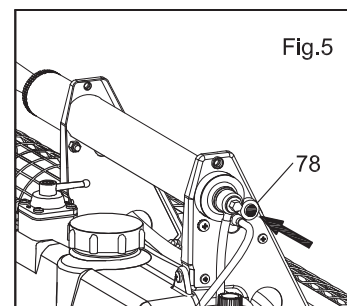

5) Fill fuel tank with normal grade gasoline, without any additives. There is no advantage to use premium gasoline with a higher octane rating. Always use gasoline funnel(144) with filter. We recommend to fill the tank at least 2/3 full. (Fig. 6)

 Never fill the fuel tank when the fogger is hot.

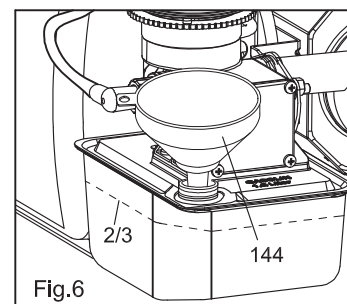

6) After filling, tighten gasoline cap (7) firmly by hand. Push stop button (52) of gasoline control fully to stop position. (Fig. 7)

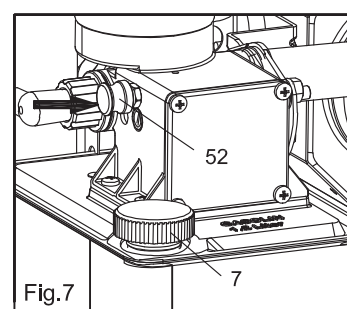

7) Tighten the drainage cap before filling solution tank (1). Always use solution funnel (143) with strainer. (Fig. 8)

 Only prepare sufficient fogging mixture as required.

 NEVER fill the fuel into the solution tank (1).

8) Fit fog solution tank cap (2) securely. Make sure that solution tap (120) is closed (lever pointing inwards). (Fig. 9)

9) Tighten the air intake valve (30) and swirl vane (26). (Fig. 10)

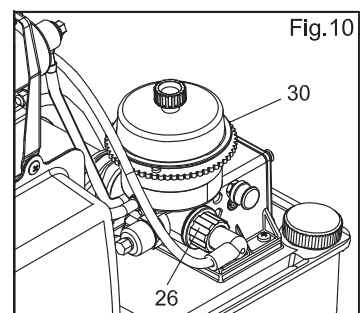
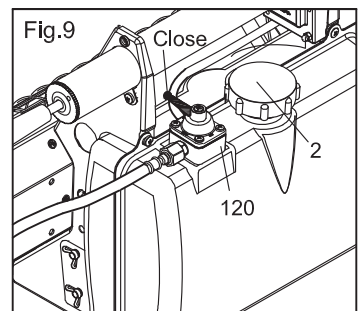
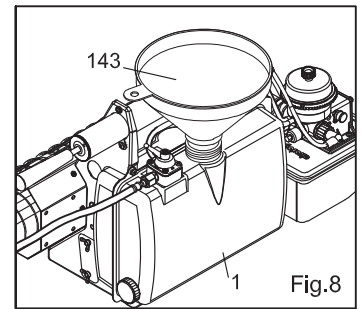

7. Selection of solution nozzle and fog tube:

Metering nozzle (measured with water):

nozzle size Ø	flow rate L/H, approx.
0.6	5
0.7	8
0.8	12
1.0	18
1.2	23
1.4	36
1.6	42

The flow rate will vary according to viscosity of the fog mixture. Always check calibration with the actual fog mixture to be used.

For **water based** solutions choose nozzles up to Ø1.0 mm. For better performance, we recommend special fog tube (109) and fog solution socket (114/1) for water based product. Use fog tube in position marked for WATER.

For **oil based** solutions we recommend nozzle sizes Ø 0.8 and above. Use the standard oil-base fog tube (108) ONLY. Use fog tube in position marked for OIL.

Smaller nozzles reduce the droplet size. Larger nozzles with excessive flow rate will increase droplet size.



Never operate the fogger with water based fog tube when using oil based fogging mixtures as this can lead to over heating and potential fire risk.

8. Preparation of Fogging Mixture:

Products to be applied as fogs include insecticides for fly/mosquito control, wood preservatives, biocides for disinfection/fumigation, and others that are required to be applied as fogs.

To generate a fine thick fog, typically a carrier oil is necessary in the mixture of the product to be applied. For oil based or ULV (ultra low volume) applications, kerosene is normally used as a diluent. For water misible products, water is the diluent only or a 10% glycol mix in water is used as an alternative to generate a thick fog. In this case, particle sizes are slightly larger and fogs are less visible.

Typical diluents are:

- For preparations miscible with water:
 1. pure water
 2. special fog carriers, e.g. glycerin, glycols
 3. white oils with suitable emulgators
 4. a mixture of 1. and 2. or 1. and 3.

- For preparations miscible with oil:
 5. diesel oil, heating oil or kerosene
 6. white oils and vegetable oils in a viscosity similar to diesel oil
 7. special fog carriers



When fogging indoor, it is essential to take fire precautions to prevent fire risk. These include, extinguishing all naked flames and turning off electricity. Not to fog more than 1 liter per 400m³ with oil-based formulations applied in kerosene as a spark or naked flame can ignite the fog.



Always follow manufacturer's recommendations on the product label.

9. Starting the Fogger:

- 1) Pull stop button (52) outwards to open fuel valve. (Fig. 11)

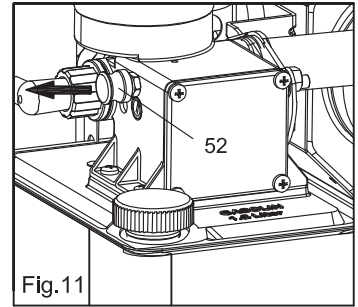

- 2) Press starter button (78) and hold while actuating the air pump to pressurize the fuel tank. Pump regularly and evenly till engine ignites with a low audible pulse note. At the first ignite, release starter button but pump another 1-2 strokes. The engine should run without more pumping. (Fig. 12)

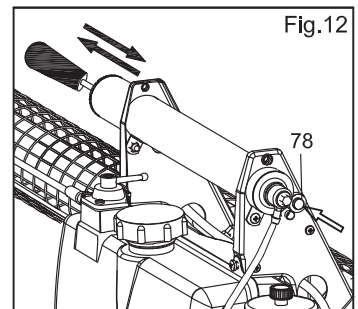

 Lower fuel level in the tank, more pumping strokes are required to start the engine. When possible, always start with a full tank.

 Make sure fuel volume is sufficient for the intended fogging period.

- 3) After starting, let the fogger warm up for about 1 minute.
 - open the solution tap (120) by turning the lever pointing outwards, liquid will flow and fog will form.
 - close the solution tap (120) to stop fogging. (Fig. 13)

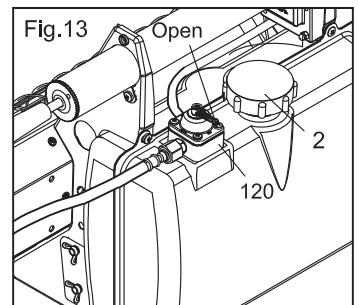

 All E models have an emergency cut-off valve (EC), always check that the valve is operating correctly. See section 15 "Emergency Cut-off Device".

10. If fogger Stops Unexpectedly

Take the following measures if the fogger stops unexpectedly.

- Close the solution tap (120) immediately. This will prevent the solution being injected into the hot resonator by the over-pressure in the solution tank. If the solution is injected, there is a risk of combustible mixture coming into contact with the hot resonator and combustion chamber and igniting accidentally. (Fig. 14)

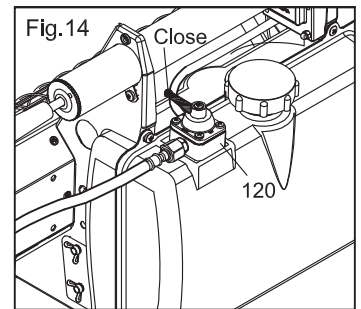

Normally emergency cut-off device fitted on E models will automatically prevent the solution being injected when fogger is not operating.

- Hold the fogger with fog tube pointing downwards. This is precautionary measure to ensure no solution flows back onto the hot resonator / combustion chamber. (Fig. 15)

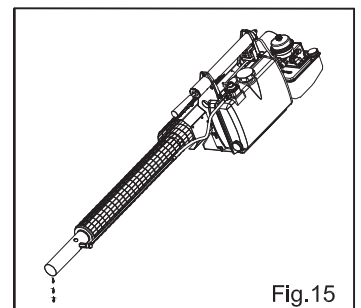

Never leave the fogger unattended while in operation.

11. Stopping the Fogger:

- 1) Close solution tap (120) by 1/4 turn to clear or ventilate the solution pipe (116). (Fig. 16)

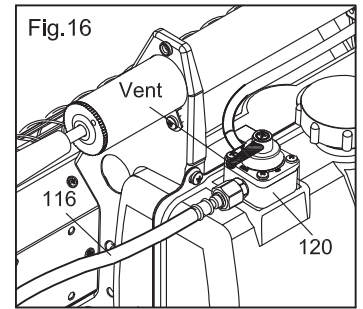

- 2) Wait until fog is no longer visible. Close solution tap (120) completely (lever inwards). (Fig. 17)

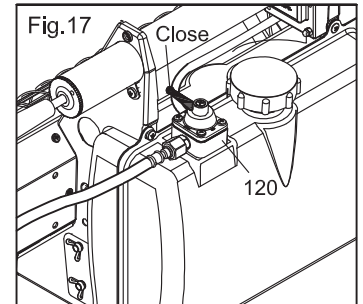

- 3) Press stop button (52) until fogger stops pulsing. (Fig. 18)

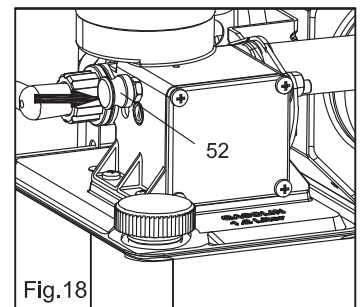

- 4) Release pressure from solution tank by unscrewing solution tank cap (2) by 1 to 2 turns then re-tighten the cap. (Fig. 19)

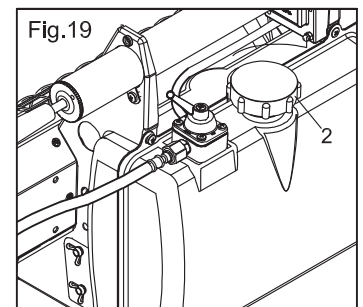



After fogging is stopped always release pressure from solution tank as this is still under pressure and solution can flow if the solution tap is opened inadvertently.

12. Adjustment of Fuel/Air Mix:

Due to atmospheric differences particularly if foggers are used at altitude it may be necessary on occasions to adjust the factory set fuel / air mixture. To do this, please fill the fuel tank at least 2/3 full then proceed with the following steps:

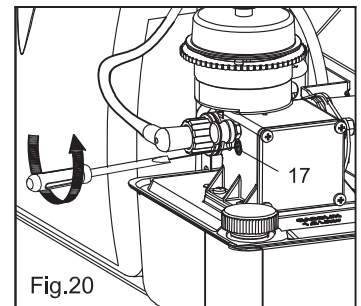
- Turn regulating needle (17) approx. 1/2 counter clockwise then start the fogger. (Fig. 20)
- Allow the fogger to warm up for at least 1 minute.
- Check the flame at the resonator (97) end by observing inside the resonator tube at a safe distance (approx. 2m)



 Wear safety glasses for protection.

- For fine adjustment, turn the regulating needle (17) clockwise or counter clockwise cautiously until the flame is no longer visible. (Fig. 21)

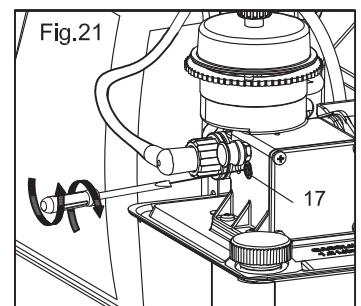

When the adjustment is correct the engine pulse note is regular and no flame appears at the resonator end.

 NEVER run the fogger over-adjustment (high frequency pulse sound, flame exiting fog tube) as this causes power loss and overheating, which may lead to fire hazard.

“FUEL OVERFLOW INTO ENGINE”:

It is possible that by too vigorous pumping the fuel overflows from the carburetor and short flames exit the fog tube, the fogger misfires. In this case, close fuel stop button (52), press starter button (78) and actuate air pump until no more misfiring is audible. Start the fogger again as normal but do not pump too vigorously, 2-3 short pumps are sufficient.

13. Maintenance & Storage:

To ensure the fogger is ready for use at all times, we recommend the following:

a) Rinse fog solution tank with a suitable cleaning agent or diluent. Pour approx. 1/4L of water in the solution tank, shake well and fog to clear pipe system.

b) Clean outside of fogger to remove dirt.

c) Remove diaphragm (33) in air intake valve (30). Check for any damage and clean. Also clean the valve body (34), the spacer plate (32) and the silencer (60) with a soft cloth. (Fig. 22)

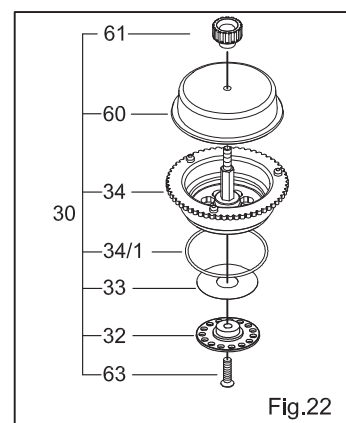

d) Remove carbon residue in resonator tube (97), solution socket (114), dosage nozzle (117) and fog tube (108) with the scraper (141) and wire brush (142). (Fig. 23)

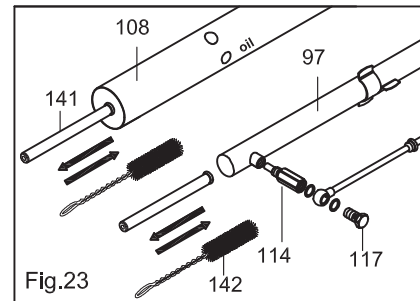

 It is important that any soot or carbon deposits at the end of the resonator tube should be removed.

- e) Clean mixing pipe of resonator (97) of combustion residues with scraper (141) and wire brush (142). (Fig. 24)

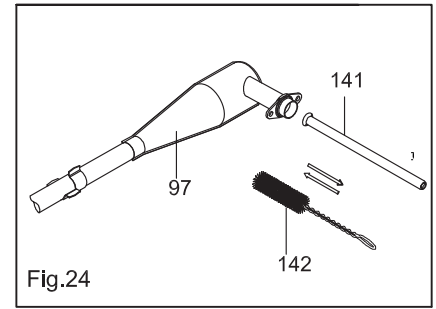

- f) Clean mixing chamber of carburettor (24) with brush (142). Take care not to damage the fuel atomizer nozzle. (Fig. 25)

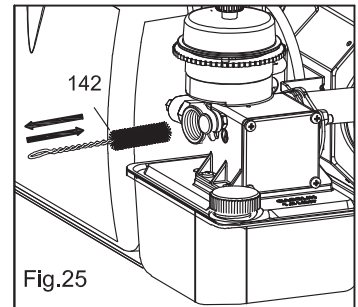

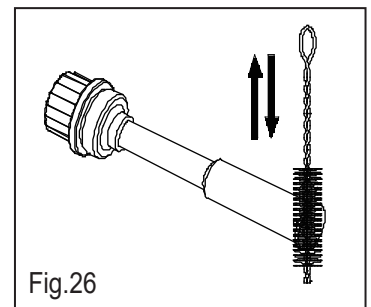

- g) Clean swirl vane with wire brush. (Fig. 26)

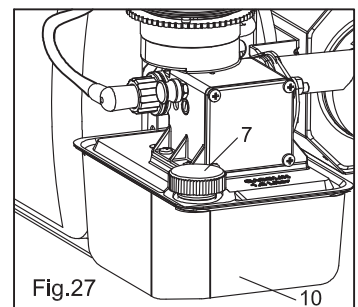

- h) Empty fuel tank (10) when the fogger is cold. Leave the cap (7) loose to allow vapours to escape. (Fig. 27)



-  Remove batteries from the fogger when it is to be stored for a long period.

-  Store the fogger at the place where it is not accessible to children and persons who are unaware of danger which is involved.

14. Trouble Shooting:

- Only trained and qualified personnel is authorized to do repairs.
- Use only original spare parts.
- Before maintenance or repair, stop the fogger and allow a cooling time. Always remove the spark plug socket from the swirl vane.
- During repair and test, at all times avoid touching electrically live components.
- After repair, reassemble the safety devices (e.g. protection guards) and check for correct assembly of all parts.
- After each repair, do a functional fogging test with the neat water.
- It is recommended that you have the fogger checked regularly by a suitably qualified technician (e.g. by the approved manufacturer's representative).



PLEASE FEEL FREE TO CONTACT US OR YOUR LOCAL DISTRIBUTOR FOR TECHNICAL ASSISTANCE.

Check first:

- Are all three caps of gasoline and solution tank closed and sealed well?
Check also the gaskets of the caps.
- Is there gasoline in the fuel tank?
- Check the orientation and condition of the batteries.
- If there is an audible buzz from the ignition coil when the starter button is depressed? if not replace batteries.
- Release of pressure in emergency cut off device (E models)

Possible causes:

Check:

- | | |
|--|--|
| - no ignition | - battery weak or lose contact, starter button or ignition coil faulty, swirl vane dirt or wet, mixing tube of resonator blocked with carbon deposits |
| - no gasoline supply | - gasoline supply is insufficient
blockage at gasoline supply <ul style="list-style-type: none">● unscrew regulating needle (17), actuate air pump (91), gasoline should appear● if fuel tank cap seals well |
| - water in the gasoline | - empty and clean fuel tank, refill with gasoline |
| - atomizer dirty or clogged | - clean only with gasoline and compressed air |
| - diaphragm in the air intake valve damaged or dirty | - clean or replace as necessary |
| - carburetor dirty | - clean the mixing chamber only with brass brush and gasoline, clean with compressed air |
| - resonator dirty | - remove combustion residues from resonator (97) end and the mixing pipe with scraper and brass brush |
| - wrong adjustment of fogger | - see para. (12) "Adjustment of Fuel/Air Mix" |

If the fogger runs but does not fog or fogs irregularly:

Check first:

- Is there sufficient solution in the tank?
- If the pressure hose is correctly installed?
- If the solution conveying parts are blocked or leaked?

Possible causes: Check:

- | | |
|---|---|
| - no or insufficient press in solution tank (1) | - solution tank leaks |
| | - check valve is clean or defective <ul style="list-style-type: none">● when replacing diaphragm (40), always replace it together with o-ring (41) and gasket (42) |
| | - connecting links (43) loose or damage <ul style="list-style-type: none">● when necessary, always replace it together with gasket (44) |
| | - ventilating air line (133) and pressure hose (134) leaks or damages |
| | - residue in double hollow screw (132) clean with fine wire if necessary |
| | - tank cap (2) leaks <ul style="list-style-type: none">● check gasket (4) and replace if necessary |
| - solution tap (120) defective or clogged | - the gaskets (125, 126) damage, replace it if necessary <ul style="list-style-type: none">● clean all parts of solution tap before re-assembly and check for leakage |
| - dosage nozzle (117) clogged | - clean with fine wire for free passage |
| - fog solution socket (114) clogged | - clean with fine wire for free passage |

15. Emergency Cut-off Device

All models (35ES, 9ES, 35EP, 9EP) are equipped with emergency cut-off device (EC). EC is designed to prevent liquid flow when the engine has stopped. As it is pre-set at the manufacture, adjustment is not required in normal operating conditions. In the case of repair or blockage when the adjustment is necessary, please take following steps:

The fine adjustment of the Bowden Cable (EC23) can only be set when the engine is warm (Fig. 28):

- Adjust the tension of the Bowden Cable by tuning the screw-type nipple (EC25) inwards / outwards.
- After correct adjustment, tighten the nut (EC24).

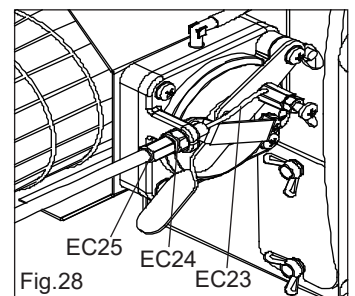

Always check the function of "EC" when starting E models. The fogger can only be operated when "EC" functions correctly.

Check EC function after adjustment:

- 1) Start the engine and run about 1 minute for warm up. Engage the lever (EC13), it should be held open automatically. Stop the engine, the lever should be released immediately. (Fig. 29)

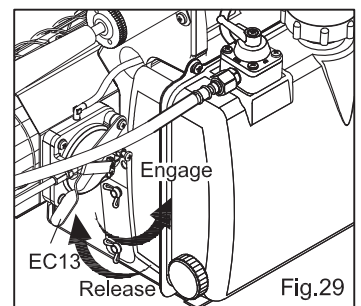

- 2) Start the engine once more. Engage the lever and open solution tap (120), fog should be seen emitted. (Fig. 30)

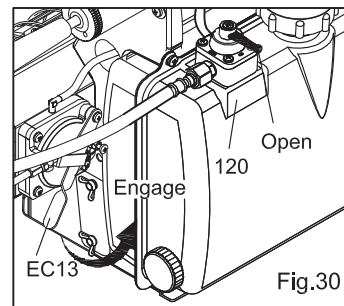

- 3) Stop the engine, lever will be released automatically, fogging should stop. (Fig. 31)

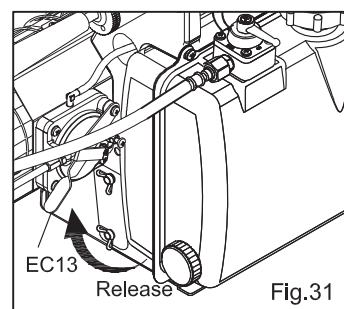

- 4) Check there is no solution leak from screw housing (EC27), valve housing (EC33) and dosage nozzle (117). (Fig. 32)

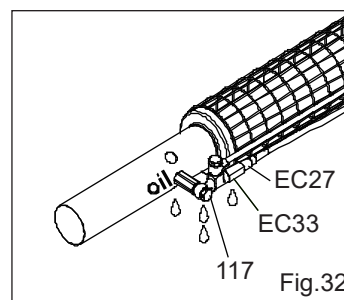

After every EC function check, immediately close the solution tap (120) and release pressure from solution tank by loosen the tank cap.

16. Fogging with EC:

- Engage the lever (EC13) and ck its position by piston.
- For fogging, open the solution tap (120), lever outwards.
- In order to stop fogging with the EC engaged, close the solution tap, lever inwards.
(Fig. 33)

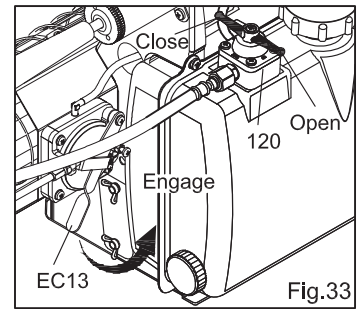

17. Stop the Fogger with EC:

1. To stop the fogger with EC, firstly refer to para. 11 (Stopping the Fogger).
2. If the fogger stops unexpectedly due to a lack of fuel or other failure :

- EC is released automatically and stops liquid flow.
- Close the solution tap (120) completely (lever inwards) and release pressure from the solution tank by loosening tank cap (2) immediately. Otherwise, solution tank is still under pressure and the solution can get out when the lever is activated by mistake.
(Fig. 34)

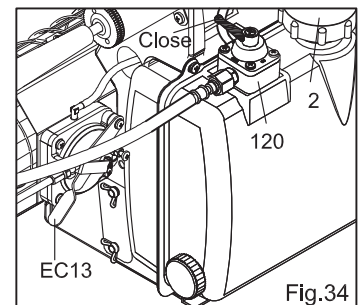

18. If EC does not function correctly:

Check first:

- Fogger runs correctly so there is sufficient air pressure to open EC.

Possible causes: Check:

- | | |
|--|---|
| <ul style="list-style-type: none">- fogger stops, operating lever does not release automatically | <ul style="list-style-type: none">- incorrect setting of screw type nipple (EC25) at the Bowden cable (EC23)- piston (EC8) is not pushed back into initial position.- spring (EC9) too weak or broken- the diaphragm (EC6) of the pressure cell is damaged or dirty |
| <ul style="list-style-type: none">- fogger engine runs but lever can not engage | <ul style="list-style-type: none">- incorrect setting of screw type nipple (EC25) at the Bowden cable (EC23)- piston (EC8) is not pushed forward- spring (EC9) too strong- the diaphragm (EC6) of the pressure cell is damaged or dirty- leak of pressure in the "EC" system- clog of air pressure tube (EC20) |
| <ul style="list-style-type: none">- fogger in operation and lever releases, fog does not stop | <ul style="list-style-type: none">- incorrect setting of screw type nipple (EC25) at the Bowden cable (EC23)- spring (EC28) too weak or broken- damage of o-ring (EC32)- valve housing (EC33) dirty |

-
- fogger in operation and lever engage, no fog
 - incorrect setting of screw type nipple (EC25) at the Bowden cable (EC23)
 - damage of Bowden cable (EC23)
 - clog of valve housing (EC33) or dosage nozzle (117) or solution socket (114)
 - solution tap (120) does not open

 - solution leaks out of screw housing (EC27) or valve housing (EC33) or solution socket (114) when appliance stops, operating lever releases and solution tap opens.
 - damage of o-ring (EC31)
 - damage of o-ring (EC32)
 - spring (EC28) too weak or broken

Exploded Drawing

35ES & 9ES

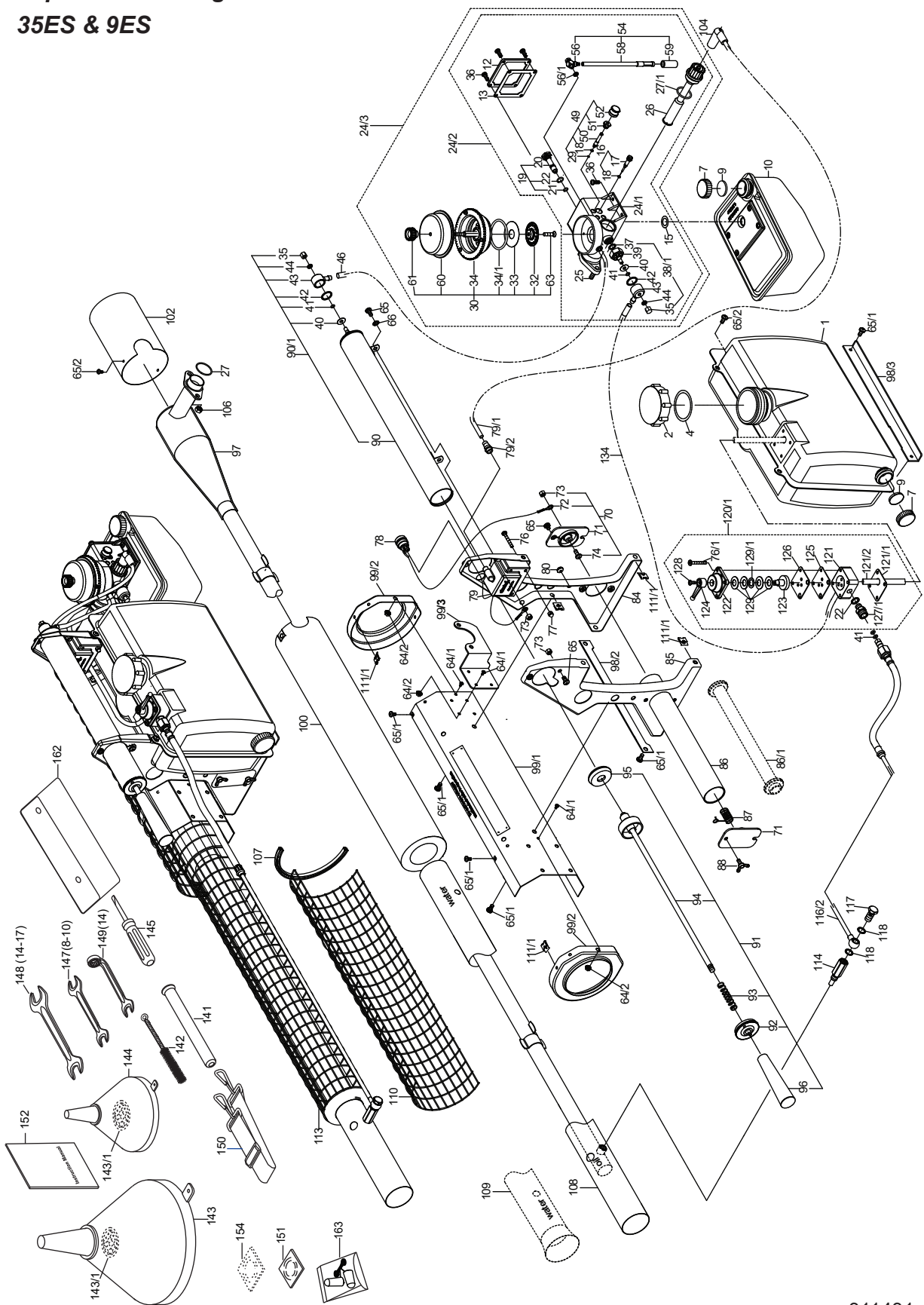

311431

Microfog Thermal Fogger 9ES / 35ES Spare Part List

When ordering spare parts, please always mention the pos., part number, descriptions, number of parts needed.

note: the part without “ # ” is commonly suitable for all appliance types.
the part with “ # ” can only be used on particular mentioned appliance type.

Pos.	Part no.	Description
1	935-001-100	Solution Tank
2	935-002-000	Tank Cap, cpl.
4	935-004-000	O-Ring
7	935-007-000	Cap, cpl.
9	935-009-000	Gasket
10	935-010-100	Fuel Tank
12	935-012-000	Carburettor Cover
13	935-013-000	Gasket
15	909-015-000	O-Ring
16	935-016-000	Regulating Needle, cpl. (17,18)
17	935-017-000	Regulating Needle
18	935-018-000	O-Ring
19#	935-019-000	Atomizer Nozzle, cpl. (20-22), 35ES
19#	909-019-000	Atomizer Nozzle, cpl. (20-22), 9ES
20#	935-020-000	Atomizer Nozzle, 35ES
20#	909-020-000	Atomizer Nozzle, 9ES
21	935-021-000	O-Ring
22	935-022-000	O-Ring
23/5	909-023-050	Cap
24/3#	935-024-030	Carburettor, cpl., 35ES
24/3#	909-024-030	Carburettor, cpl., 9ES
24/2#	935-024-020	Carburettor Assembly, 35ES
24/2#	909-024-020	Carburettor Assembly, 9ES
25	935-025-000	Set Screw, M6x20
26#	935-026-000	Swirl Vane, 35ES
26#	909-026-000	Swirl Vane, 9ES
27#	935-027-000	O-Ring, 35ES
27#	909-027-000	O-Ring, 9ES
27/1	935-027-010	O-Ring
29	935-029-000	O-Ring
30#	935-030-100	Air Intake Valve, cpl. (32,33,34,34/1,60,61,63), 35ES
30#	909-030-100	Air Intake Valve, cpl. (32,33,34,34/1,60,61,63), 9ES
32#	935-032-100	Spacer Plate, 35ES
32#	909-032-100	Spacer Plate, 9ES
33	935-033-100	Diaphragm
34	935-034-100	Valve Body
34/1	935-034-010	O-Ring
35	935-035-000	Cap Nut, M5
36	935-036-000	Fill. Head Screw, M4x12
37	935-037-000	Gasket
38/1	935-038-010	Check Valve, cpl. (35,39-44)
39	935-039-000	Check Valve
40	935-040-000	Diaphragm
41	935-041-000	O-Ring
42	935-042-000	Gasket

Pos.	Part no.	Description
43	935-043-000	Connecting Link
44	935-044-000	Gasket
46	935-046-000	Air Tube
49	935-049-000	Gasoline Stop Button, cpl. (50-52,18,29)
50	935-050-000	Plunger
51	935-051-000	Bushing
52	935-052-000	Button
54	935-054-000	Gasoline Suction Line, cpl. (56,58,59)
56	935-056-000	Screw Fitting
56/1	935-056-010	Gasket
58	935-058-000	Hose with Filter
59	935-059-000	Felt Tube
60	935-060-000	Silencer
61	935-061-000	Kunrled Nut
63	935-063-000	Countersunk Head Screw, M5x20
64/1		Frame Screw, M4x8
64/2		Hexagon Frame Nut
65	935-065-000	Fill. Head Screw, M5x10
65/1		Screw ST 4.2x10
65/2		Screw ST 4.2x6
66	935-066-000	Tooth Lock Washer
70	935-070-000	Contact Plate Assembly (71-74)
71	935-071-000	Battery Cover
72	935-072-000	Cable
73	935-073-000	Nut, M5
74	935-074-000	Fill. Head Screw, M5x12
76	935-076-00	Fill. Head Screw, M4x30
76/1	935-076-010	Fill. Head Screw, M4x35
77	935-077-000	Cap Nut, M4
78	935-078-000	Starter Button
79	935-079-000	Ignition Coil
79/1	935-079-010	Spark Pulg Cable
79/2	935-079-020	Grommet
80	935-080-000	Grommet
82	935-082-000	Label (Series of Batteries)
84	909-084-010	Support, Blue
85	909-085-010	Support, Blue
86	935-086-000	"LR20/D" Battery Holder
86/1	935-086-010	"LR6/AA" Battery Holder, Optional
87	935-087-000	Contact Spring
88	935-088-000	Wing Screw, M5x10
89/1	909-089-010	Pump, cpl. (90/1, 91)
90	909-090-000	Pump Tube
90/1	909-090-010	Pump Tube w/ Check Valve Assembly
91	909-091-000	Pump Spindle Assembly, 92-96
92	909-092-000	Cap
93	935-093-000	Spring
94	935-094-000	Pump Spindle
95	935-095-000	Collar
96	935-096-000	Handle

Pos.	Part no.	Description
97#	935-097-000	Resonator, 35ES
97#	909-097-000	Resonator, 9ES
98/2	935-098-020	Protection Shield
98/3	935-098-030	Support Bracket
99	909-099-100	Guard Plate Assembly (99/1, 99/2, 99/3)
99/1	909-099-010	Guard Plate
99/2	909-099-020	Fixing Device
99/3	909-099-030	Bracket
100	909-100-000	Cooling Jacket
102	935-102-010	Hood
104	935-104-000	Spark Plug Socket
106	909-106-000	Hexagon Nut, M6
107	935-107-000	Edge Protection
108#	935-108-000	Universal Fog Tube, 35ES
108#	909-108-000	Universal Fog Tube, 9ES
109#	935-109-000	Water Base Fog Tube, 35ES, Optional
109#	909-109-000	Water Base Fog Tube, 9ES, Optional
110	909-110-000	Protective Cover
111/1	935-111-010	Spire Clip
113#	935-113-010	Protective Guard, 35ES
113#	909-113-010	Protective Guard, 9ES
114	935-114-000	Fog Solution Socket
116/2#	935-116-020	Solution Line Teflon, 35ES
116/2#	909-116-020	Solution Line Teflon, 9ES
117/0.8	935-117-080	Dosage Nozzle 0.8
117/1.0	935-117-100	Dosage Nozzle 1.0
117/1.2	935-117-120	Dosage Nozzle 1.2
118	935-118-000	Gasket
120/1	909-120-010	Solution Tap, cpl. (22,76/1x4,121-131)
121	909-121-000	Tap, Lower Part
121/1	909-121-010	Gasket, Viton
121/2	909-121-020	Solution Tube
122	935-122-000	Tap, Upper Part
123	935-123-000	Tap, Center Part
124	935-124-000	Clamp Handle
125	935-125-000	Gasket
126	935-126-000	Gasket
127/1	909-127-010	Screw Connection
128	935-128-000	Countersunk Head Screw
129	935-129-000	Cup Spring
129/1	935-129-010	Spacer Disc
134	900-020-000	Air Tube
141	935-141-000	Scraper
142	935-142-000	Brush
143	935-143-000	Solution Funnel, cpl. with Strainer
143/1	935-143-010	Strainer
144	935-144-000	Gasoline Funnel, cpl. with Strainer

Pos.	Part no.	Description
145	935-145-000	Screw Driver, -/+
147	935-147-000	Double Open Ended Spanner, 8-10
148	935-148-000	Double Open Ended Spanner,14-17
149	935-149-000	Spanner, 14
150	935-150-000	Carrying Strap with Pad
151	909-151-000	Diaphragm Pack
152	909-152-000	Instruction Manual
154	909-154-010	Maintenance Kit, Optional
162	935-162-000	Tool Bag
163	909-163-000	Ear Plug

Exploded Drawing 35EP, 9EP

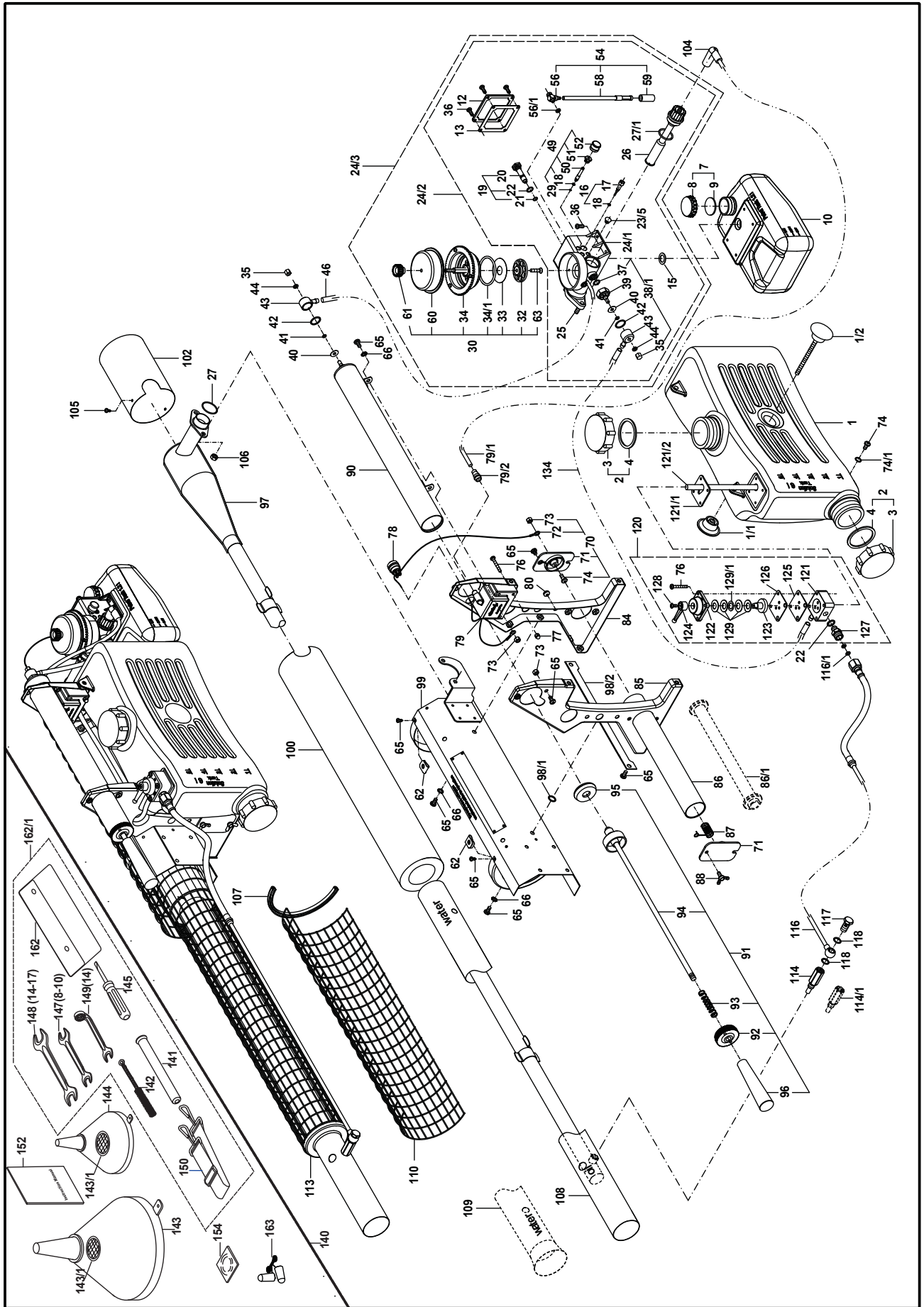

Microfog Thermal Fogger 9EP / 35EP Spare Part List

When ordering spare parts, please always mention the pos., part number, descriptions, number of parts needed.

note: the part without “ # ” is commonly suitable for all appliance types.
the part with “ # ” can only be used on particular mentioned appliance type.

Item.	Part no.	Description
1	909-001-000	Solution Tank, HDPE
1/1	909-001-020	Tube Holder
1/2	909-001-010	Tube Holder Cap
2	909-002-000	Tank Cap Assembly (3,4)
3	909-003-000	Tank Cap
4	240-034-020	Gasket
7	909-007-000	Cap Assembly (8,9)
8	909-008-000	Cap
9	935-009-000	Gasket
10	909-010-000	Fuel Tank, HDPE
12	935-012-000	Carburettor Cover
13	935-013-000	Gasket, Fiber
15	909-015-000	Gasket
16	935-016-000	Regulating Needle Assembly (17,18)
17	935-017-000	Regulating Needle
18	935-018-000	O-Ring
19#	935-019-000	Atomizer Nozzle Assembly, 35E, 35EP (20-22)
19#	909-019-000	Atomizer Nozzle Assembly, 9E, 9EP (20-22)
20#	935-020-000	Atomizer Nozzle, 35E, 35EP
20#	909-020-000	Atomizer Nozzle, 9E, 9EP
21	935-021-000	O-Ring
22	935-022-000	O-Ring
23/4	909-023-040	Set Screw, M6x5
23/5	909-023-050	Plug
24/3#	935-024-030	Carburettor cpl., 35E, 35EP
24/3#	909-024-030	Carburettor cpl., 9E, 9EP
24/2#	935-024-020	Carburettor Assembly, 35E, 35EP
24/2#	909-024-020	Carburettor Assembly, 9E, 9EP
24/1#	935-024-010	Carburettor Housing, 35E, 35EP
24/1#	909-024-010	Carburettor Housing, 9E, 9EP
25	935-025-000	Set Screw, M6x20
26#	935-026-000	Swirl Vane, 35E, 35EP
26#	909-026-000	Swirl Vane, 9E, 9EP
27#	935-027-000	O-Ring, 35E, 35EP
27#	909-027-000	O-Ring, 9E, 9EP
27/1	935-027-010	O-Ring
29	935-029-000	O-Ring
30#	935-030-000	Air Intake Valve Assembly, 35E, 35EP (32,33,34,34/1,60,61,63)
30#	909-030-000	Air Intake Valve Assembly, 9E, 9EP (32,33,34,34/1,60,61,63)

Item.	Part no.	Description
32#	935-032-000	Spacer Plate, 35E, 35EP
32#	909-032-000	Spacer Plate, 9E, 9EP
33	935-033-000	Diaphragm
34	935-034-000	Valve Boby
34/1	935-034-010	O-Ring
35	935-035-000	Cap Nut, M5
36	935-036-000	Fillister Head Screw, M4x12
37	935-037-000	Gasket, Fiber
38/1	935-038-010	Check-Valve Assembly
39	935-039-000	Check-Valve
40	935-040-000	Diaphragm, Viton
41	935-041-000	O-Ring
42	935-042-000	Gasket
43	935-043-000	Connecting Link
44	935-044-000	Gasket, Fiber
46	935-046-000	Air Tube
49	935-049-000	Gasoline Stop Button Assembly (50-52,18,29)
50	935-050-000	Plunger
51	935-051-000	Bushing
52	935-052-000	Button
54	935-054-000	Gasoline Suction Line Assembly (56,58,59)
56	935-056-000	Screw Fitting
56/1	935-056-010	Gasket
58	935-058-000	Hose with Filter
59	935-059-000	Felt Tube
60	935-060-000	Silencer
61	935-061-000	Kunrled Nut
62	935-062-000	Sheet Metal Nut, M5
63	935-063-000	Countersunk Head Screw, M5x20
65	935-065-000	Fillister Head Screw, M5x10
66	935-066-000	Tooth Lock Washer
70	935-070-000	Contact Plate with Cable (71-74)
71	935-071-000	Battery Cover
72	935-072-000	Cable
73	935-073-000	Nut, M5
74	935-074-000	Fillister Head Screw, M5x12
74/1	909-074-010	Plain Washer
76	935-076-000	Fillister Head Screw, M4x30
77	935-077-000	Cap Nut, M4
78	935-078-000	Starter Button
79	935-079-000	Ignition Coil
79/1	935-079-010	Spark Pulg Cable
79/2	935-079-020	Grommet
80	935-080-000	Grommet
84	909-084-000	Support, Blue

Item.	Part no.	Description
85	909-085-000	Support, Blue
86	935-086-000	"D" Battery Holder
86/1	935-086-010	"AA" Battery Holder
87	935-087-000	Contact Spring
88	935-088-000	Wing Screw, M5x10
89	909-089-000	Pump Assembly (90,91/1,91)
90	909-090-000	Pump Tube
90/1	909-090-010	Check-Valve, Pump Tube
91	909-091-000	Pump Spindle Assembly, 92-96
92	909-092-000	Cap
93	935-093-000	Spring
94	935-094-000	Pump Spindle
95	935-095-000	Collar
96	935-096-000	Handle
97#	935-097-000	Resonator, 35E, 35EP
97#	909-097-000	Resonator, 9E, 9EP
98/1	935-098-010	Gasket
98/2	935-098-020	Protection Shield
99	909-099-000	Fixing Device
100	909-100-000	Cooling Jacket, Black
102#	935-102-010	Hood, 35E, 35EP
102#	909-102-010	Hood, 9E, 9EP
104	935-104-000	Spark Plug Socket
105	935-105-000	Tapping Screw, 2.9x6.5 ISO 07049
106	935-106-000	Hexagon Nut, M6
107	909-107-000	Edge Protection
108#	935-108-000	Universal Fog Tube, 35E, 35EP
108#	909-108-000	Universal Fog Tube, 9E, 9EP
109#	935-109-000	Special Fog Tube for Water Base , 35E, 35EP
109#	909-109-000	Special Fog Tube for Water Base , 9E, 9EP
110	909-110-000	Protective Cover
113#	935-113-010	Protective Guard, 35E, 35EP
113#	909-113-010	Protective Guard, 9E, 9EP
114	909-114-000	Fog Solution Socket
114/1	909-114-010	Special Fog Solution Socket (Water Base)
116#	935-116-010	Solution Line Teflon, 35E, 35EP
116#	909-116-010	Solution Line Teflon, 9E, 9EP
116/1	504-007-007	O-Ring
117/0.8	909-117-080	Dosage Nozzle, 0.8
117/1.0	909-117-100	Dosage Nozzle, 1.0
117/1.2	909-117-120	Dosage Nozzle, 1.2
118	909-118-000	Gasket, CF
120	909-120-000	Solution Tap Assembly (22,76x4,121-131)
121	909-121-000	Tap, Lower Part
121/1	909-121-010	Gasket
121/2	909-121-020	Solution Tube
122	935-122-000	Tap, Upper Part

Item.	Part no.	Description
123	935-123-000	Tap, Center Part
124	935-124-000	Clamp Handle
125	935-125-000	Gasket
126	935-126-000	Gasket, Teflon
127	909-127-000	Screw Connection
128	935-128-000	Countersunk Head Screw, M4x10
129	935-129-000	Cup Spring
129/1	935-129-010	Spacer Disc
134	909-134-000	Air Tube
140#	935-140-010	Standard Accessories (143,144,152,154,162/1,163)
140#	909-140-010	Standard Accessories (143,144,152,154,162/1,163)
141	935-141-000	Scraper
142	935-142-000	Brush
143	935-143-000	Solution Funnel Assembly with Strainer
143/1	935-143-010	Strainer
144	935-144-000	Gasoline Funnel Assembly with Strainer
145	935-145-000	Screw Driver, -/+
147	935-147-000	Double Open Ended Spanner, 8x10
148	935-148-000	Double Open Ended Spanner,14x17
149	935-149-000	Spanner, 14 "L"
150	935-150-000	Carrying Strap with Pab
152	909-152-000	Instruction Manual
154#	935-154-010	Maintenance Kit, 35E, 35EP (13, 15, 21, 22, 27#, 27/1, 29, 33, 37, 59, 121/1, 125, 126, 2x(18,40,41,42,44,118))
154#	909-154-010	Maintenance Kit, 9E, 9EP (13, 15, 21, 22, 27#, 27/1, 29, 33, 37, 59, 121/1, 125, 126, 2x(18,40,41,42,44,118))
162	935-162-000	Tool Bag
162/1	909-162-010	Tool Kit (141,142,145,147,148,149,150,162)
163	935-163-000	Ear Plug

Emergency Cut-off Device "EC"

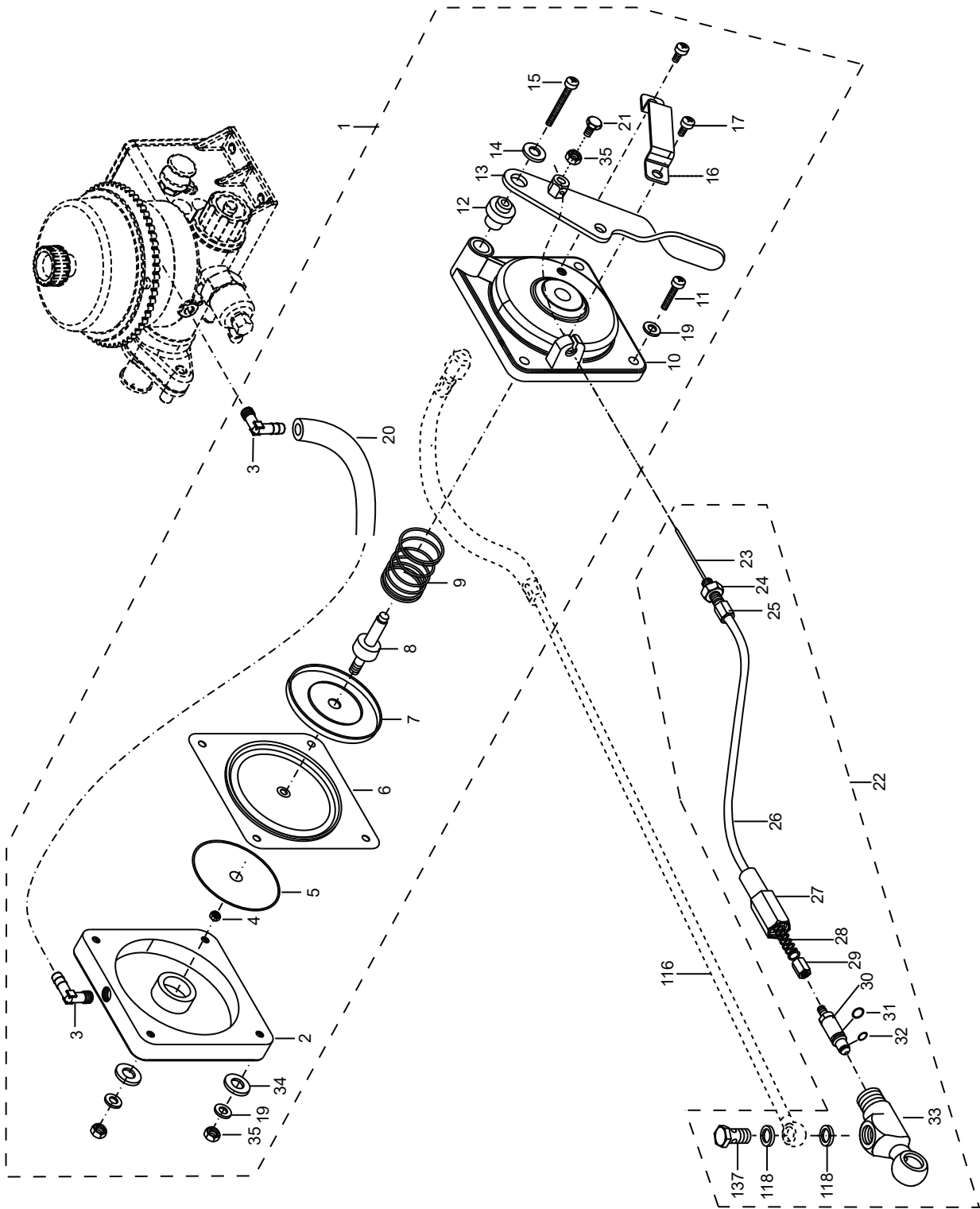

281526

Emergency Cut-off Device “EC” Spare Part List

When ordering spare parts, please always mention the pos., part number, descriptions, number of parts needed.

note: the part without “ # ” is commonly suitable for all appliance types.
the part with “ # ” can only be used on particular mentioned appliance type.

Pos.	Part no.	Description
EC-1	900-001-000	Pressure Cell, cpl.
EC-2	900-002-000	Housing Base
EC-3	900-003-010	Angle Socket
EC-4	900-004-000	Lock Nut, M4
EC-5	900-005-000	Plate
EC-6	900-006-000	Diaphragm
EC-7	900-007-000	Plate
EC-8	900-008-000	Piston
EC-9	900-009-000	Pressure Spring
EC-10	900-010-000	Housing Top
EC-11	935-130-000	Fill. Head Screw, M4x25
EC-12	900-012-000	Bearing Bush
EC-13	900-013-000	Lever
EC-14	900-014-000	Plain Washer
EC-15	900-015-000	Fill. Head Screw, M4x40
EC-16	900-016-000	Bowl
EC-17	900-017-000	Fill. Head Screw, M4x6
EC-19	900-019-000	Plain Washer
EC-20	909-134-000	Air Tube
EC-21	935-036-000	Hexagon Screw, M4x12
EC-22#	900-022-909	Bowden Cable, cpl., 9ES
EC-22#	900-022-935	Bowden Cable, cpl., 35ES
EC-23#	900-023-909	Cable, 9ES
EC-23#	900-023-935	Cable, 35ES
EC-24	935-106-000	Hexagon Nut, M6
EC-25	900-025-000	Screw -Type Nipple M6
EC-26#	900-026-909	Cable Guide, 9ES
EC-26#	900-026-935	Cable Guide, 35ES
EC-27	900-027-000	Screw Housing
EC-28	900-028-000	Pressure Spring
EC-29	900-029-000	Nut, M4
EC-30	900-030-000	Plunger
EC-31	935-041-000	O-Ring
EC-32	260-040-000	O-Ring
EC-33	900-033-010	Valve Housing
EC-34	935-056-010	Gasket
EC-35	935-131-000	Hexagon Nut, M4
118	935-118-000	Gasket
137	935-137-000	Hollow Screw
	900-036-010	Maintenance Kit (6,31,32)x1, 118x2, 34x4

NOTE

General Enquiries

MICRON GROUP

Bromyard Industrial Estate
Bromyard, Herefordshire
HR7 4HS U.K.

T +44 (0)1885 482397

F +44 (0)1885 483043

E enquiries@microngroup.co.uk

GOIZPER GROUP

Antigua, 4
20577 Antzuola
Gipuzkoa – Spain

T + 34 943 786 000

E goizper@goizper.com

www.microngroup.com

www.goizper.com



Copyright © Micron Sprayers Ltd. 2020